

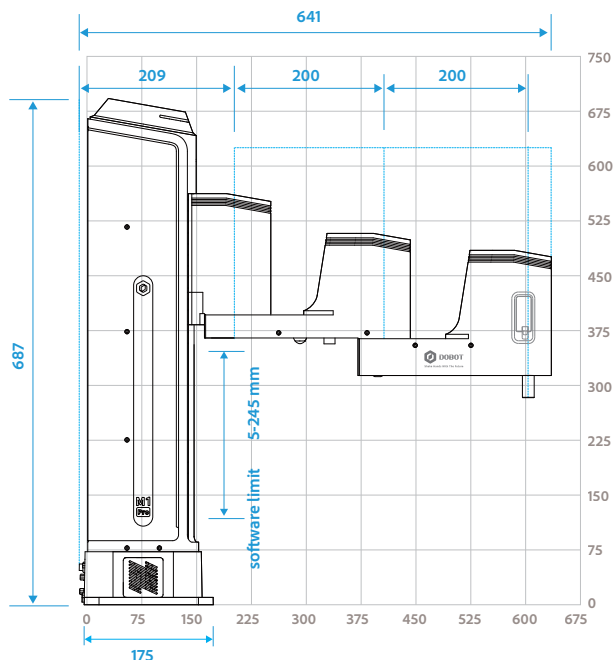

DOBOT M1 Pro

www.dobot-robotics.hu
info@dobot-robotics.hu



Product Name DOBOT M1 Pro
 Product Model DT-M1-P4R15-011

Controlled Axes 4
 Rated Load 1.5kg
 Max. Reach 400 mm
 Repeatability ± 0.02 mm

Motion Parameters	Joint	Motion Range	Max. Speed
	J1	$\pm 85^\circ$	180 °/s
	J2	$\pm 130^\circ$	180 °/s
	J3	5mm ~ 245mm	1000mm/s
	J4	$\pm 360^\circ$	1000 °/s

Power Input 100~240 V AC, 50/60 Hz
 Rated Voltage DC 48 V
 Rated Power 192 W
 Communication TCP/IP, Modbus TCP
 Installation Desktop
 Weight 15.7 kg
 Base Dimension 230 mm \times 175 mm
 Work Environment 0 °C~40 °C
 Software DobotStudio 2020, SCStudio

Interface

Base :	Digital Input	16
	Digital Output	16
	Ethernet	2
	USB 2.0	2
	Encoder Input	1
	Emergency Stop	1
End :	Digital Input	4
	Digital Output	4

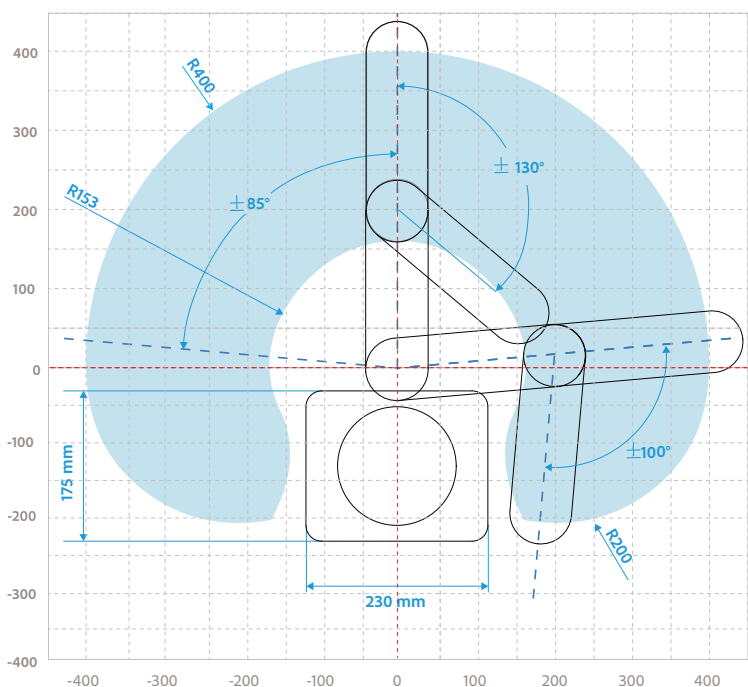
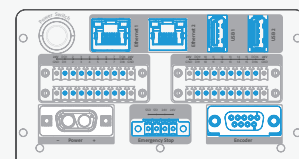

Mounting Drawing

